

2015 GEMBOREE COMPETITION SCHEDULE

GENERAL CONDITIONS:

All sections will be judged according to the rules and conditions of the "Competitor & Judging Manual for Lapidary & Allied Competitions", issue no. 7 dated April 2006, unless otherwise stated in this schedule.

This is a **LEVEL 4** Competition.

The Competition Committee may transfer an entry to its correct Section if they are of the opinion that it has obviously been entered in the wrong Section.

All inquiries **MUST** be directed to the Competition Co-ordinator, Peter Krake, phone (03) 5825 2778 OR e-mail: landpkrake@netspace.net.au OR posted to:

Competition Co-ordinator
P O Box 500
MOOROOPNA VIC 3629.

Entrants are responsible for insurance of their entries whilst in transit and in the possession of the GEMBOREE Committee.

Competition Section Abbreviations:

O = OPEN DIVISION
I = INTERMEDIATE DIVISION
N = NOVICE DIVISION
J = JUNIOR DIVISION
C = JUDGED AS CRAFTSMANSHIP
AA = JUDGED AS AESTHETIC APPEAL
SC = SPECIAL CONDITION

Entry Forms:

Entry Forms for ALL Sections **MUST** be received at PO Box 500 MOOROOPNA VIC 3629 by Saturday 31st January 2015, together with a flat fee of \$6.00 per Competitor, together with a stamped self-addressed envelope for return of receipt, and enough funds to cover cost of return Registered Post (if required). Receipt for Entry Form will be sent after receipt of posted entries. Entries on late Entry Forms will not be eligible for competition, they will be for display only.

Note:

Please make all cheques payable to: 'Victorian Gem Clubs Association Inc. GEMBOREE Account'.

Actual Entries:

Entries in Groups 1, 2, 3, 4, 5, 7, 8, 9, 10, 11, 12, 13, 14, 18, 19, 20, 21, 23, 24, 25 and Sections 26A & 26B **MUST** be mailed to P.O. Box 500 MOOROPNA VIC 3629 to arrive no later than Saturday 31st January 2015. Receipt for these entries and the Entry Form will be sent by mail upon receipt of the actual entries.

Late entries will not be eligible for competition, they will be for display only.

NOTE: All mail entries **MUST** be sent by Registered Post or Express Post.

Entries in Groups 16, 17, 27, 28, 29, 31, 32, 34, 37 & 99 and Section 26C **MUST** be delivered to the Competition Committee at the Gem Show Hall between 1.00pm and 5.00pm on Thursday 2nd April 2015. Receipt for these entries will be provided upon receipt of the actual entries.

To be eligible for competition, these entries MUST have their approximate dimensions, in mm, entered onto the entry form.

Entries not set up by 6:00pm will not be eligible for competition, they will be for display only.

Return Of Entries:

Entries in Groups 16, 17, 27, 28, 29, 31, 32, 34, 37 & 99 and Section 26C **MUST** be picked up from the Gem Show Hall between 3.00pm and 5.00pm on Monday 6th April 2015. Receipt and proof of identity (where appropriate) must be given.

Entries in Groups 1, 2, 3, 4, 5, 7, 8, 9, 10, 11, 12, 13, 14, 18, 19, 20, 21, 23, 24, 25 and Sections 26A & 26B **MAY** be collected from the Gem Show Hall between 5.00pm and 6.00pm on Monday 6th April 2015. Receipt and proof of identity (where appropriate) must be given.

Entries not collected as above will be returned by Registered mail by Friday 8th May 2015.

Entrants who are unable to provide their entries receipts WILL have to wait until ALL receipt holding Entrants have collected their entries first.

Judging Sheets:

MAY be collected from the Gem Show Hall between 3.00pm and 4.00pm Saturday 4th April 2015. Receipts and proof of identity (where appropriate) must be given. If not collected they will be returned with entries.

Awards & Trophies:

Medallions will be awarded and engraved as appropriate and will be displayed with the entry during the GEMBOREE.

Perpetual Trophies will be engraved with the winners' name and will be displayed during the GEMBOREE after which they will be retained by the GEMBOREE Committee. This saves entrants the expense of returning them to the next GEMBOREE Committee and also ensures that the Committee has them when next required.

The winner of each Perpetual Trophy will be presented with an appropriately engraved Keep Trophy during an Award Ceremony held during the GEMBOREE.

Annual Trophies will be engraved with the winners' name and will be presented during an Award Ceremony held during the GEMBOREE.

Trophies and medallions won by entrants not attending the GEMBOREE will be forwarded with their entries and judging sheets.

Overseas Entrants:

- Will be deemed to be "Open Division", except Juniors.
- Will not be charged an entry fee due to the high costs associated with currency exchange.
- Are advised to clearly label their packages "Lapidary Competition Entries to be Returned". It is also advisable to include a copy of the entry form in the package. Experience has shown that this minimizes possible Customs queries both in Australia and in the country of origin.

Don't Forget!
Please get your Entry Form in
NOW!

SPECIAL CONDITIONS:

- 'A'** Standard Cabochons & Double Standard Cabochons **MUST** have a definite 'Oval Shape' to be Eligible in this Competition.
Unless otherwise specified in the schedule:
Any material may be used.
Minimum Size - 20mm on the longest dimension across the outline shape.
Maximum Size - 60mm on the longest dimension across the outline shape.
- 'B'** Minimum Size - the dimension specified in the schedule is the diameter of a circular hole through which the 'Entry' must **NOT** be able to pass.
Maximum Size - 50mm in any direction.
- 'C'** Minimum Size - 10mm on the longest dimension across the outline shape.
Maximum Size - 20mm on the longest dimension across the outline shape.
Shape - Any Shape - including round and oval.
- 'D'** To be Eligible the Entry **MUST** accurately represent the design depicted on the supplied cutting diagram and comply with the material specifications.
To be Eligible, coloured stones **MUST** be obviously coloured while colourless stones **MUST** show no sign of colour - Entries will be checked by viewing through the culet when placed on a piece of white tissue.
- 'E'** Magnification for Judging will be 'By Eye'.
- 'F'** To be Eligible the Entry **MUST** be a Brooch, Pendant, Necklace or Bracelet.
Section O.18F may include the use of 'Beads' (*Lapidary Material*) to compliment the Lapidary Item/s. If 'Beads' are used, they must not dominate.
- 'G'** Location - Entries are to be from Any Origin.
Minimum Size - 25mm on the longest dimension of any specimen, single or part of a group.
Maximum Size - 300mm on the longest dimension for any 'Single' or 'Group of Specimens'
Maximum Height - 100mm.
- 'H'** Location - Unless otherwise specified, **ALL** Entries are to be from Australia.
Size - **ALL** Entries are to be Miniature or Cabinet Size.
- 'I'** To be Eligible the Showcase **MUST** contain a majority of items that are of a nature suitable for this type of competition. The use of lacquer on lapidary items is **NOT** permitted.
Eligibility will be determined by the Competition Committee.
Eligible Showcases will be numbered, with the winner being decided by a public ballot held during the show.

COMPETITION SECTIONS:

GROUP 1 & 2: CABOCHON - SC 'A'

O.1A/C	Standard Cabochon - Specified Size 40mm x 30mm - NOT Agate
I.1A/C	Standard Cabochon - Ribbonstone
N.1A/C	Standard Cabochon
J.1A/C	Standard Cabochon
O.1A/AA	Standard Cabochon - Minimum Size 35mm on longest axis - Agate
I.1A/AA	Standard Cabochon
N.1A/AA	Standard Cabochon
O.1B/C	Fancy Cabochon - Minimum Size 35mm on longest dimension across outline shape - Obsidian
I.1B/C	Fancy Cabochon - Petrified Wood
N.1B/C	Fancy Cabochon
J.1B/C	Fancy Cabochon
O.1B/AA	Fancy Cabochon - Tiger's Eye - Any colour (<i>Tiger Iron <u>NOT</u> Accepted</i>)
I.1B/AA	Fancy Cabochon - Agate
N.1B/AA	Fancy Cabochon
J.1B/AA	Fancy Cabochon
O.2A/C	Double Standard Cabochon - Specified Size 40mm x 30mm - Agate
I.2A/C	Double Standard Cabochon
N.2A/C	Double Standard Cabochon
O.2B/C	Double Fancy Cabochon - Minimum Size 35mm on longest dimension across outline shape
O.2B/AA	Double Fancy Cabochon - Minimum Size 35mm on longest dimension across outline shape
I.2B/AA	Double Fancy Cabochon
N.2B/AA	Double Fancy Cabochon

GROUP 3: FREE FORM - SC 'B'

O.3/C	Solid Opal - 10mm
I.3/C	Banded Agate - 15mm
N.3/C	Banded Agate - 15mm
J.3.1/C	Any Material - 10mm
J.3.2/C	Solid Opal - 10mm
O.3/AA	Banded Agate - 25mm
I.3/AA	Any Material - 15mm
N.3/AA	Any Material - 15mm

GROUP 4: OPAL - SC 'C'

O.4B/C	Opal Doublet - Domed Top
N.4B/C	Opal Doublet - Domed Top

IMPORTANT

To ensure your Entries are eligible, please refer to the information contained in the Competitor & Judging Manual No. 7 **AND** the Special Conditions on page 22 of this Schedule.

GROUP 5: CARVING - “Known Form” - Any Hardness

- O.5A Fully 3-Dimensional
- I.5A Fully 3-Dimensional
- N.5A Fully 3-Dimensional
- J.5A Fully 3-Dimensional (*MUST Be of a “Known Form”*)
- O.5B In Relief

GROUP 7: SPHERE

- O.7A/AA Sphere

GROUP 8 to 11: FACET CUTS - SC ‘D’

- O.8A Standard Brilliant - Continuous Girdle - Specified Size
8mm - Natural Australian Amethyst
- I.8A Standard Brilliant - Continuous Girdle - Specified Size
8mm - Natural Australian Amethyst
- N.8B Standard Brilliant - Faceted Girdle - Coloured Cubic Zirconia
- J.8B Standard Brilliant - Faceted Girdle - Coloured Cubic Zirconia
- O.9A Standard Oblong Step Cut with Cut Corners - Specified Size
6mm x 9mm - Natural Australian Citrine
- I.9A Standard Oblong Step Cut with Cut Corners - Minimum Size
8mm x 12mm - Natural Australian Citrine
- N.9B Standard Square Step Cut with Cut Corners - Coloured Natural
Quartz
- J.9B Standard Square Step Cut with Cut Corners - Coloured Natural
Quartz
- O.10.1 OMNI Shield - Coloured Topaz
- O.10.2 Ultra-Brilliant Cushion - Coloured Man Made Corundum
- I.10 Compare 1:1.40 - Colourless Topaz
- N.10.1 Novice Cushion Triangle - Coloured Man Made Corundum
- N.10.2 Brilliant Cushion - Colourless Topaz
- O.11 Briolette - Minimum Size 8mm (*Across Girdle*) - Coloured Natural
Quartz
- I.11 Joker - Minimum Size 10mm - Coloured Man Made Spinel

IMPORTANT

To ensure your Entries are eligible, please refer to the information contained in
the Competitor & Judging Manual No. 7

AND the Special Conditions on page 22 of this Schedule.

GROUP 12: TUMBLED STONES - 15mm - SC 'B'

- O.12A Pre-Formed Shape - Set of 3 - Each to be a different species or variety
N.12A Pre-Formed Shape - Set of 3 - Any Material

GROUP 13: POLISHED FACE - FLAT SURFACE

- O.13/AA Agate
N.13/AA Any Material

GROUP 14: POLISHED FACE - CURVED SURFACE

- O.14/AA Any Material
N.14/AA Any Material

GROUP 16: GEM TREES - SC 'E'

- O.16 Group of Trees - minimum of two on one base
N.16 Single Tree

GROUP 17: NOVELTY GEMCRAFT - SC 'E'

- O.17 Novelty Gemcraft
N.17 Novelty Gemcraft

GROUP 18: HAND-FABRICATED AND WIRE WRAPPED JEWELLERY - SC 'F'

- O.18A NOT intended to include lapidary, fossil or mineral items
I.18A NOT intended to include lapidary, fossil or mineral items
N.18A NOT intended to include lapidary, fossil or mineral items
O.18B.1 WITH lapidary item/s cut and set by Entrant - Material - Solid Opal
O.18B.2 WITH lapidary item/s cut and set by Entrant - Material - NOT Opal
I.18B WITH lapidary item/s cut and set by Entrant
N.18B WITH lapidary item/s cut and set by Entrant
O.18C WITH natural fossil or mineral specimen/s set by Entrant
O.18E WITH lapidary, fossil or mineral item/s prepared and set by Entrant
I.18E WITH lapidary, fossil or mineral item/s prepared and set by Entrant
N.18E WITH lapidary, fossil or mineral item/s prepared and set by Entrant
J.18E WITH lapidary, fossil or mineral item/s prepared and set by Entrant
O.18F WITH commercial lapidary item/s set by Entrant

IMPORTANT

To ensure your Entries are eligible, please refer to the information contained in the Competitor & Judging Manual No. 7

AND the Special Conditions on page 22 of this Schedule.

**GROUP 19: CAST JEWELLERY USING PATTERNS, MOULDS
AND DIES MADE BY THE ENTRANT - SC 'F'**

O.19A NOT intended to include lapidary, fossil or mineral item/s

**GROUP 20: CAST JEWELLERY USING NATURAL OBJECTS
AS PATTERNS - SC 'F'**

O.20A NOT intended to include lapidary, fossil or mineral item/s

N.20A NOT intended to include lapidary, fossil or mineral item/s

**GROUP 21: CAST JEWELLERY USING COMMERCIAL WAX MODELS
OR PATTERNS - SC 'F'**

O.21A NOT intended to include lapidary, fossil or mineral item/s

I.21A NOT intended to include lapidary, fossil or mineral item/s

N.21A NOT intended to include lapidary, fossil or mineral item/s

GROUP 23: COMBINED JEWELLERY - SC 'F'

O.23B WITH lapidary item/s cut and set by Entrant

GROUP 24: ENAMELLED JEWELLERY - SC 'F'

O.24A Enamelled Jewellery in Hand Fabricated Setting

**GROUP 25: COMMERCIAL MOUNT JEWELLERY WITH
LAPIDARY ITEM/S CUT AND SET BY ENTRANT**

O.25 Commercial Mount Jewellery

I.25 Commercial Mount Jewellery

N.25 Commercial Mount Jewellery

J.25 Commercial Mount Jewellery

GROUP 26: ENAMELLING - SC 'F' (Jewellery Only)

O.26A Enamelled Jewellery in Commercial Mount

O.26B Enamelled Jewellery Without Mount

N.26B Enamelled Jewellery Without Mount

O.26C Enamelled Non-Jewellery (*MUST Be Functional*)

N.26C Enamelled Non-Jewellery (*MUST Be Functional*)

GROUP 27: GENERAL METALCRAFT

O.27A NOT intended to include lapidary, fossil or mineral item/s

N.27A NOT intended to include lapidary, fossil or mineral item/s

GROUP 28: SHEET METALWORK

O.28A Bas Relief or Impressed Pattern

GROUP 29 to 31: SHOWCASES

- O.29B General - Lit
O.31 Novelty - Any Theme

GROUP 32: FOSSILS NON-DISPLAY - SC 'G'

- O.32A.1 Single Specimen - Vertebrate - NOT Tooth or Claw
O.32A.2 Single Specimen - Vertebrate - Tooth or Claw
N.32A Single Specimen - Any Type
J.32A Single Specimen - Any Type
O.32B Group of 3 - Mixed
N.32B Group of 3 - Any Type
J.32B Group of 3 - Any Type

GROUP 34: MINERALS NON-DISPLAY - SC 'H'

- O.34A.1 Single Crystal - Faceting Quality
O.34A.2 Single Specimen - Overseas
N.34A.1 Single Crystal - Other than Faceting Quality
N.34A.2 Single Specimen - Overseas
J.34A Single Crystal - Other than Faceting Quality
O.34B.1 Group of 3 Crystal Clusters
O.34B.2 Group of 3 Specimens - each to be a different species Overseas
O.34B.3 Group of 3 Specimens - Zeolites - each to be a different species
N.34B.1 Group of 3 Crystal Clusters
N.34B.2 Group of 3 Specimens - each to be a different species
J.34B Group of 2 Crystal Clusters

GROUP 37: MINERAL SHOWCASE - DISPLAY

- O.37B Lit
N.37B Lit

GROUP 99: POPULAR CHOICE SHOWCASE - SC 'I'

- 99 Popular Choice Showcase

IMPORTANT

To ensure your Entries are eligible, please refer to the information contained in the Competitor & Judging Manual No. 7

AND the Special Conditions on page 22 of this Schedule.

PERPETUAL TROPHIES and CONDITIONS:

PT-04 Ray Powell - CHAMPION CLUB

Club with highest aggregate members' points.

Points allocated to entries in each Section as follows:

20 points for highest scoring entry/entries.

15 points for the 2nd highest scoring entry/entries.

10 points for the 3rd highest scoring entry/entries.

5 points for the 4th highest scoring entry/entries.

Donor - Gem & Lapidary Council of NSW Inc.

ANNUAL TROPHIES and CONDITIONS:

PT-01 Tom Jenkins - OPEN - CHAMPION LAPIDARY

Entrant with the highest aggregate score of their best entry in each of the following 5 Open Sections:

O.1A/C Standard Cabochon

O.1B/C Fancy Cabochon

O.2B/C Double Fancy Cabochon

O.4B/C Opal Doublet

O.10.2 Ultra-Brilliant Cushion

Donor - Victorian Gem Clubs Association Inc.

PT-02 Harold Evans - INTERMEDIATE - CHAMPION LAPIDARY

Entrant with the highest aggregate score of their best entry in each of any 3 of the following 4 Intermediate Sections:

I.1A/C Standard Cabochon

I.3/AA Free Form

I.9A Standard Oblong Step Cut with Cut Corners

I.25 Commercial Mount Jewellery with Lapidary Item/s Cut & Set by Entrant

Donor - Victorian Gem Clubs Association Inc.

PT-03 Norm Patison - NOVICE - CHAMPION LAPIDARY

Entrant with the highest aggregate score of their best entry in each of any 4 of the following 5 Novice Sections:

N.1A/C Standard Cabochon

N.1B/C Fancy Cabochon

N.2A/C Double Standard Cabochon

N.8B Standard Brilliant - Faceted Girdle

N.25 Commercial Mount Jewellery with Lapidary Item/s Cut & Set by Entrant

Donor - P. Murphy & T. Annear via AFLACA Trophy Fund.

AT-01 Dorothy Caladine - JUNIOR - CHAMPION LAPIDARY

Entrant with the highest aggregate score of their best entry in each of a minimum of 3 of the following 5 Junior Sections:

J.1A/C	Standard Cabochon
J.1B/C	Fancy Cabochon
J.3.1/C	Free Form
J.3.2/C	Free Form - solid opal - minimum size 10mm
J.25	Commercial Mount Jewellery with Lapidary Item/s Cut & Set by Entrant

Donor - Rhonda Sabella

**AT-02 Kadesa Gems & Minerals - OPEN - HAND FABRICATED
JEWELLERY with NO LAPIDARY ITEMS**

Entrant with highest scoring entry in:

Section O.18A - Hand-Fabricated Jewellery NOT Intended to include Lapidary, Fossil or Mineral items.

Donor - Kadesa Gems & Minerals

AT-03 Dorothy Caladine - JUNIOR - CARVING

Entrant with highest scoring entry in:

Section J.5A - Carving - Fully 3-Dimensional 'Known Form' 'Any Hardness'.

Donor - Rhonda Sabella

AT-04 The Crystal Habit Trophy - BEST MINERAL OF THE SHOW

Donor selects winning entry from all minerals on display, whether in competition or not. Display specimens belonging to Dealers or Institutions are NOT eligible for this award.

Donor - Peter Beckwith

AT-05 Val Annear - OPEN - ENAMELLING - NON-JEWELLERY

Entrant with highest scoring entry in:

Section O.26C - Enamelling Non-Jewellery

Donor - Victorian Gem Clubs Association Inc.

In memory of Tony Annear.

**AT-06 John S. Ryding - OPEN - HAND MADE JEWELLERY with
NATURAL FOSSIL or MINERAL SPECIMEN/S**

Entrant with highest scoring entry in:

Section O.18C

Donor - Mrs. J. Ryding via AFLACA Trophy Fund.

- AT-07 Harry Miller** - OPEN - STANDARD CABOCHON/AA
Entrant with highest scoring entry in:
Section O.1A/AA - Standard Cabochon.
Donor - Mrs. D. Miller via AFLACA Trophy Fund.
- AT-08 Earth Stones** - BEST FOSSIL OF THE SHOW
Donor selects winning entry from all fossils on display, whether
in competition or not. Display specimens belonging to Dealers or
Institutions are NOT eligible for this award.
Donor - Mr. Jon Mommers
- AT-09 George Lude** - OPEN - 3 AUSTRALIAN CRYSTAL CLUSTERS
Entrant with highest scoring entry in:
Section O.34B.1 - Minerals Non-Display - Group of Specimens.
‘Crystal Clusters’ ‘Australian’
Donor - Queensland Lapidary & Allied Craft Clubs Association, Inc.
- AT-10 Alex Amess** - OPEN - FACET CUT
Entrant with highest scoring entry in:
Section O.10.2 - Ultra-Brilliant Cushion
Donor - Victorian Gem Clubs Association Inc.
- AT-11 A & E Metal Merchants** - OPEN - HAND MADE JEWELLERY with
LAPIDARY ITEM/S
Entrant with highest scoring entry in:
Section O.18B.2
Donor - A & E Metal Merchants
- AT-12 Jim Johnson** - NOVICE - CHAMPION MINERAL ENTRANT
Entrant with the highest aggregate score of their best entry in each of a
minimum of any 3 of the Novice Mineral Sections - including Showcase.
*Donor - Gem & Mineral Clubs Association of SA Inc.
and others via AFLACA Trophy Fund.*
- AT-13 Broken Hill Centenary** - OPEN - CHAMPION MINERAL ENTRANT
Entrant with the highest aggregate score of their best entry in each of
a minimum of 3 Open Mineral Sections.
Donor - AFLACA
- AT-14 Ted Koller** - OPEN - SOLID OPAL CUT
Entrant with highest scoring entry in:
Section O.3/C - Free Form
Donor - Victorian Gem Clubs Association Inc.

- AT-15 Dazlyn Gems** - JUNIOR - STANDARD CABOCHON/C
Entrant with highest scoring entry in:
Section J.1A/C - Standard Cabochon
Donor - Dazlyn Gems
- AT-16 Peter Collins** - OPEN - CHAMPION FACETOR
Entrant with the highest aggregate score of their best entry in each of the following 3 Open Faceting Sections:
O.9A Standard Oblong Step Cut with Cut Corners
O.10.1 OMNI Shield
O.11 Briolette
If tied, the Entrant with the highest points scoring entry will be the winner.
Donor - Australian Facetors' Guild Ltd.
- AT-17 Arthur Roffey** - OPEN - SHOWCASE GENERAL - LIT
Entrant with highest scoring entry in:
Section O.29B - Showcase General - Lit
Donor - Arthur Roffey
- AT-18 Boris Novic** - OPEN - DOUBLE STANDARD CABOCHON/C
Entrant with highest scoring entry in:
Section O.2A/C - Double Standard Cabochon
Donor - Gem & Lapidary Council of NSW Inc.
- AT-19 Patrick C Murphy** - JUNIOR - CHAMPION MINERAL ENTRANT
Junior entrant's highest aggregate score of their best entries in each of a minimum of 3 Mineral Sections, irrespective of Division - including Showcase.
Donor - Arthur Roffey
- AT-20 Cyril Kovac** - OPEN - MINERAL SHOWCASE - DISPLAY- LIT
Entrant with highest scoring entry in:
Section O.37B
Donor - Cyril Kovac of C K Minerals
- AT-21 Brian Bown** - OPEN - STANDARD CABOCHON/C
Entrant with highest scoring entry in:
Section O.1A/C - Standard Cabochon
Donor - Brian Bown

AT-22 Jack Bushby - NOVICE CHAMPION FACETOR

Entrant with the highest aggregate score of their best entry in each of the following 3 Novice Faceting Sections:

- | | |
|--------|---|
| N.9B | Standard Square Step Cut with Cut Corners |
| N.10.1 | Novice Cushion Triangle |
| N.10.2 | Brilliant Cushion |

If tied, the Entrant with the highest points scoring entry will be the winner.

Donor - Southern Rockhounds

AT-23 Dick Moppett - OPEN - STANDARD FACET CUTS

Entrant with the highest aggregate score of their best entry in each of the following 2 Open Faceting Sections:

- O.8A - Standard Brilliant - Continuous Girdle
- O.9A - Standard Oblong Step Cut with Cut Corners

Both cut from Specified Natural Australian Material

Donor - Gem & Lapidary Council of NSW Inc.

AT-24 Chas Totterdell - OPEN - HAND MADE JEWELLERY with OPAL

Entrant with highest scoring entry in:

Section O.18B.1

Donor - Gem & Lapidary Council of NSW Inc.

AT-25 The Lapidary Club of Victoria - OPEN - CARVING

Entrant with highest scoring entry in:

Section O.5A

Donor - Victorian Gem Clubs Association Inc.

AT-26 Gold Coast School of Wirecraft - WIRE WRAPPED JEWELLERY

Entrant with highest scoring entry in:

Section N.18E

Donor - Sir Paul Howard

ANNUAL TROPHIES (AT-27 & AT-28) and SPECIAL TROPHIES

Continued on next page!

IMPORTANT

To ensure your Entries are eligible, please refer to the information contained in the Competitor & Judging Manual No. 7

AND the Special Conditions on page 22 of this Schedule.

AT-27 The Tony Annear OAM Memorial Trophy

Highest aggregate score of the Entrant's best entry in the following Sections: *(Regardless of Division/s Entered!)*

- Fancy Cabochon - Section 1B
- Free Form - Section 3
- Carving - Section 5A
- Modified Standard Cut - Section 10
- Faceting Fancy Cut - Section 11
- Tumbled Stones - Section 12A
- Polished Flat Face - Section 13
- Novelty Gemcraft - Section 17
- Hand Fabricated Jewellery with Lapidary item/s - Section 18B
- Mineral Group of 3 Specimens - Section 34B

Donor - AFLACA Trophy Fund.

AT-28 Queensland Gem Clubs Association - CAST JEWELLERY

Highest individual scoring entry in any of the Cast Jewellery Sections. *(Regardless of Division/s Entered!)*

- Cast Jewellery - Section 19A
- Cast Jewellery - Section 20A
- Cast Jewellery - Section 21A

Donor - Queensland Gem Clubs Association Inc.

SPECIAL TROPHIES and CONDITIONS:

ST-01 Senior Princess - GEMBOREE Senior Princess

Entrant Chosen and Crowned by GEMBOREE organisers.

Donor - Victorian Gem Clubs Association Inc.

ST-02 Junior Princess - GEMBOREE Junior Princess

Entrant Chosen and Crowned by GEMBOREE organisers.

Donor - Tasmanian Lapidary & Mineral Association Inc.

ST-03 Best Presented Trade Stand - BEST PRESENTED TRADE STAND

Commercial Dealer whose 'Stand' is judged 'Best Presented' by someone appointed by the Donor, OR GEMBOREE Committee.

Donor - Shepparton & District Gem Club Inc.

IMPORTANT

To ensure your Entries are eligible, please refer to the information contained in the Competitor & Judging Manual No. 7

AND the Special Conditions on page 22 of this Schedule.

OPEN / INTERMEDIATE SECTIONS 0.8A & I.8A

Material: Natural Australian Amethyst
 Specified Size: 8mm
 Facets: 58
 Meets: 41 (crown: 24, pavilion: 17)

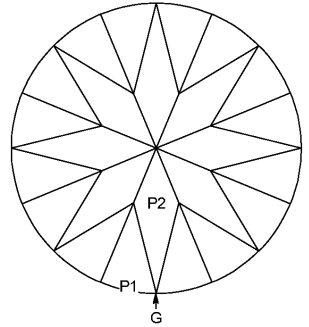
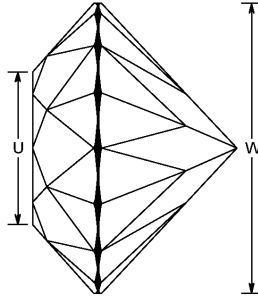
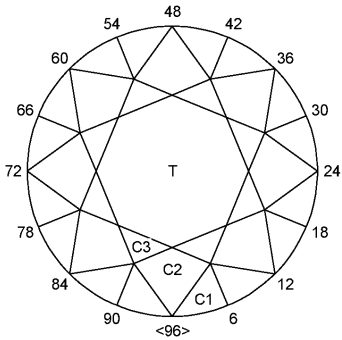

Standard Brilliant - Continuous Girdle

Computer Work by Rick Parker, for GEMBOREE 2015.

Angles for R.I. = 1.540

57 + 1 girdle = 58 facets

8-fold, mirror-image symmetry

96 index

$L/W = 1.000$ $T/W = 0.527$ $U/W = 0.527$

$P/W = 0.476$ $C/W = 0.223$

$Vol./W^3 = 0.245$

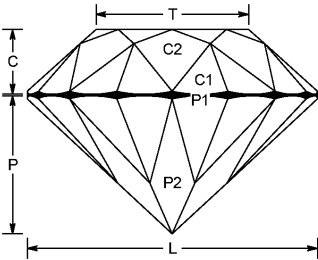

PAVILION

P1 45.00° 03-09-15-21-27-33-39-45-51-57-63-69-75-81-87-93 TCP

G 90.00° cut to size 'rolled girdle'

P2 43.00° 96-12-24-36-48-60-72-84 meet P1-P1 at girdle, PCP

CROWN

C1 47.00° 03-09-15-21-27-33-39-45-51-57-63-69-75-81-87-93 set girdle width

C2 42.00° 96-12-24-36-48-60-72-84 meet C1-C1 at girdle

C3 26.00° 06-18-30-42-54-66-78-90 meet C2-C2-C1-C1

T 0.00° Table meet C3-C3-C2

2015 GEMBOREE COMPETITION ENTRY FORM

Mail to: **Competition Co-ordinator**
P. O. Box 500
MOOROPNA VIC 3629

NOTE: Prior to entering this competition, to ensure eligibility, Entrants SHOULD read the complete COMPETITION SCHEDULE.
(Please Print Clearly)

Name:

Address:

..... State: Postcode:

Phone: (.....) Mobile:

DOB (if Junior):/...../..... Under 16 on 31st January 2015

e-mail:

Club: (full name)

'PRE-JUDGED' ENTRIES

Section	#	Section	#	Section	#	Section	#	Section	#
O.1A/C		I.1A/C		N.1A/C		J.1A/C		O.1A/AA	
I.1A/AA		N.1A/AA		O.1B/C		I.1B/C		N.1B/C	
J.1B/C		O.1B/AA		I.1B/AA		N.1B/AA		J.1B/AA	
O.2A/C		I.2A/C		N.2A/C		O.2B/C		O.2B/AA	
I.2B/AA		N.2B/AA		O.3/C		I.3/C		N.3/C	
J.3.1/C		J.3.2/C		O.3/AA		I.3/AA		N.3/AA	
O.4B/C		N.4B/C		O.5A		I.5A		N.5A	
J.5A		O.5B		O.7A/AA		O.8A		I.8A	
N.8B		J.8B		O.9A		I.9A		N.9B	
J.9B		O.10.1		O.10.2		I.10		N.10.1	
N.10.2		O.11		I.11		O.12A		N.12A	
O.13/AA		N.13/AA		O.14/AA		N.14/AA		O.18A	
I.18A		N.18A		O.18B.1		O.18B.2		I.18B	
N.18B		O.18C		O.18E		I.18E		N.18E	
J.18E		O.18F		O.19A		O.20A		N.20A	
O.21A		I.21A		N.21A		O.23B		O.24A	
O.25		I.25		N.25		J.25		O.26A	
O.26B		N.26B							

Pre-Judged Entries:

Entries in the sections listed in the 'Pre-Judged' Entries table on the opposite page MUST be sent by 'Registered Post' or 'Express Post', preferably with this Entry Form. Entries MUST be received no later than Saturday 31st January 2015. Please write the number of entries (1 or 2) in the space to the right of the section name in the table opposite.

Judged at Show Entries:

Entries in the sections listed in the following table MUST be delivered to the Competition Committee at the Gem Show Hall.

Entries MUST be delivered between 1.00pm and 5.00pm on Thursday 2nd April 2015.

Entrant MUST write approximate dimensions for each section entry in the correct spaces to the right of the section name in the following table.

NOTE: Dimensions are to be of the **complete entry only** NOT of each part of an entry. Please record all measurements in millimetres (mm) only.

'JUDGED AT SHOW' ENTRIES

Section	Entry # 1			Entry # 2			Section	Entry # 1			Entry # 2		
	W	D	H	W	D	H		W	D	H	W	D	H
O.16							N.16						
O.17							N.17						
O.26C							N.26C						
O.27A							N.27A						
O.28A							O.29B						
O.31							O.32A.1						
O.32A.2							N.32A						
J.32A							O.32B						
N.32B							J.32B						
O.34A.1							O.34A.2						
N.34A.1							N.34A.2						
J.34A							O.34B.1						
O.34B.2							O.34B.3						
N.34B.1							N.34B.2						
J.34B							O.37B						
N.37B							99						

Total Number of Entries: Entry Fee (\$6 Flat Rate): \$ 6.00

Will Collect Entries: (Tick) 'OR' Return (Registered) Postage: \$00

Your Signature: Total Enclosed: \$00

Please make all cheques payable to: 'Victorian Gem Clubs Association Inc. GEMBOREE Account'.

NOVICE / JUNIOR SECTIONS N.8B & J.8B

Material:
Facets: 73

Coloured Cubic Zirconia
Meets: 57 (crown: 32, pavilion: 25)

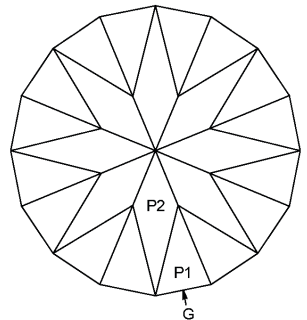
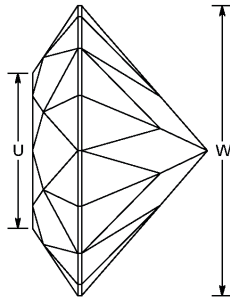
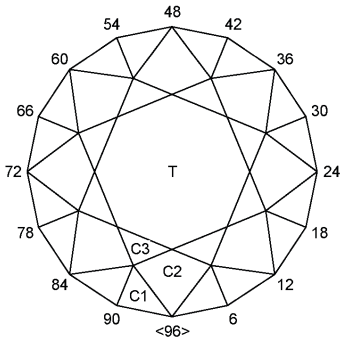

Standard Brilliant - Faceted Girdle

Computer Work by Rick Parker, for GEMBOREE 2015.

Angles for R.I. = 2.170

57 + 16 girdles = 73 facets

8-fold, mirror-image symmetry

96 index

L/W = 1.000 T/W = 0.536 U/W = 0.536

P/W = 0.435 C/W = 0.156

Vol./W³ = 0.200

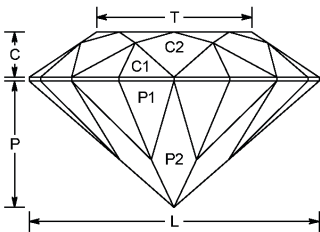

PAVILION

P1	43.00°	03-09-15-21-27-33-39-45-51-57-63-69-75-81-87-93	TCP
G	90.00°	03-09-15-21-27-33-39-45-51-57-63-69-75-81-87-93	set size
P2	41.00°	96-12-24-36-48-60-72-84	meet P1-P1 at girdle, PCP

CROWN

C1	39.00°	03-09-15-21-27-33-39-45-51-57-63-69-75-81-87-93	set girdle width
C2	34.00°	96-12-24-36-48-60-72-84	meet C1-C1 at girdle
C3	20.00°	06-18-30-42-54-66-78-90	meet C1-C1-C2-C2
T	0.00°	Table	meet C2-C3-C3

OPEN SECTION 0.9A

Material: Natural Australian Citrine
 Specified Size: 6mm x 9mm
 Facets: 53
 Meets: 44 (crown: 24, pavilion: 20)

60 48 36

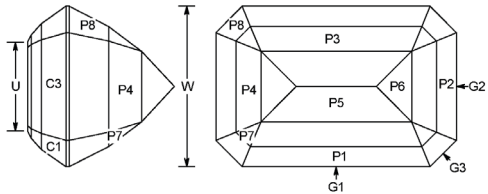
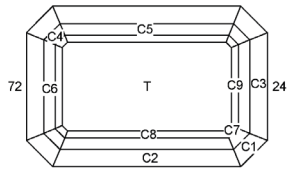

84 <96> 12

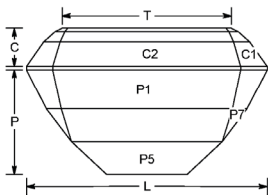

Standard Oblong Step Cut with Cut Corners

Computer Work by Rick Parker, for GEMBOREE 2015.

Angles for R.I. = 1.540

45 + 8 girdles = 53 facets

2-fold, mirror-image symmetry

96 index

L/W = 1.500 T/W = 1.054 U/W = 0.554

P/W = 0.656 C/W = 0.240

Vol./W³ = 0.744

PAVILION

G1	90.00°	96-48	set width
G2	90.00°	24-72	set length
P1	63.00°	96-48	cut as required, size by eye, form girdle
P2	63.00°	24-72	level girdle
P3	53.00°	96-48	cut as required, size by eye
P4	53.00°	24-72	meet P1-P2-P3
P5	43.00°	96-48	cut as required, size by eye, form keel
P6	43.00°	24-72	meet P3-P4-P5
P7	53.00°	12-36-60-84	meet P3-P4-P5-P6
P8	63.00°	12-36-60-84	meet P1-P3-P7
G3	90.00°	12-36-60-84	level girdle

CROWN

C1	55.00°	12-36-60-84	set girdle width
C2	55.00°	96-48	level girdle
C3	55.00°	24-72	level girdle
C4	42.00°	12-36-60-84	cut as required, size by eye
C5	42.00°	96-48	meet C1-C2-C4
C6	42.00°	24-72	meet C1-C3-C4
C7	26.00°	12-36-60-84	cut as required, size by eye
C8	26.00°	96-48	meet C4-C5-C7
C9	26.00°	24-72	meet C4-C6-C7
T	0.00°	Table	cut as required, size by eye

Most of the proportions of this stone are achieved by cutting facets 'cut as required, size by eye'
 NOT by using a meetpoint sequence.

INTERMEDIATE SECTION I.9A

Material: Natural Australian Citrine
 Minimum Size: 8mm x 12mm
 Facets: 53
 Meets: 44 (crown: 24, pavilion: 20)

60 48 36

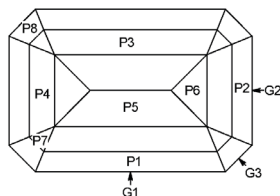
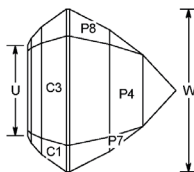
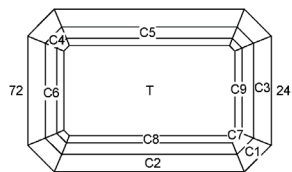

84 <96> 12

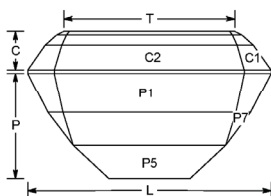

Standard Oblong Step Cut with Cut Corners

Computer Work by Rick Parker, for GEMBOREE 2015.

Angles for R.I. = 1.540

45 + 8 girdles = 53 facets

2-fold, mirror-image symmetry

96 index

L/W = 1.500 T/W = 1.054 U/W = 0.554

P/W = 0.656 C/W = 0.240

Vol./W³ = 0.744

PAVILION

G1	90.00°	96-48	set width
G2	90.00°	24-72	set length
P1	63.00°	96-48	cut as required, size by eye, form girdle
P2	63.00°	24-72	level girdle
P3	53.00°	96-48	cut as required, size by eye
P4	53.00°	24-72	meet P1-P2-P3
P5	43.00°	96-48	cut as required, size by eye, form keel
P6	43.00°	24-72	meet P3-P4-P5
P7	53.00°	12-36-60-84	meet P3-P4-P5-P6
P8	63.00°	12-36-60-84	meet P1-P3-P7
G3	90.00°	12-36-60-84	level girdle

CROWN

C1	55.00°	12-36-60-84	set girdle width
C2	55.00°	96-48	level girdle
C3	55.00°	24-72	level girdle
C4	42.00°	12-36-60-84	cut as required, size by eye
C5	42.00°	96-48	meet C1-C2-C4
C6	42.00°	24-72	meet C1-C3-C4
C7	26.00°	12-36-60-84	cut as required, size by eye
C8	26.00°	96-48	meet C4-C5-C7
C9	26.00°	24-72	meet C4-C6-C7
T	0.00°	Table	cut as required, size by eye

Most of the proportions of this stone are achieved by cutting facets 'cut as required, size by eye'
 NOT by using a meetpoint sequence.

NOVICE / JUNIOR SECTIONS N.9B & J.9B

Material:

Coloured Natural Quartz

Facets: 53

Meets: 45 (crown: 24, pavilion: 21)

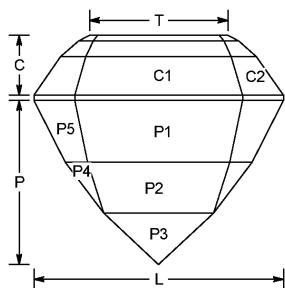
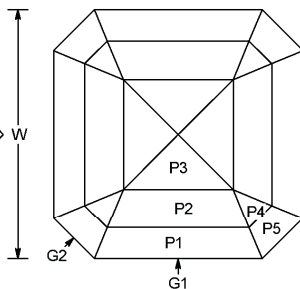
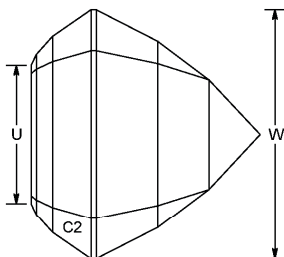
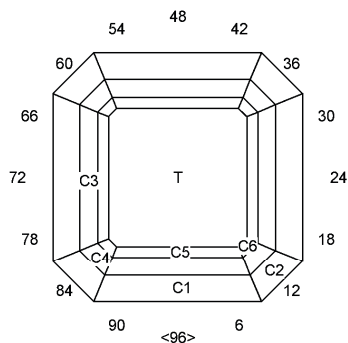

Standard Square Step Cut with Cut Corners

Computer Work by Rick Parker, for GEMBOREE 2015.

Angles for R.I. = 1.540

45 + 8 girdles = 53 facets

4-fold, mirror-image symmetry

96 index

L/W = 1.000 T/W = 0.554 U/W = 0.554

P/W = 0.656 C/W = 0.240

Vol./W³ = 0.444

PAVILION

P1	63.00°	96-24-48-72	TCP
G1	90.00°	96-24-48-72	set size
P2	53.00°	96-24-48-72	cut as required, size by eye, TCP
P3	43.00°	96-24-48-72	cut as required, size by eye, PCP
P4	53.00°	12-36-60-84	meet P2-P2-P3-P3
P5	63.00°	12-36-60-84	meet P1-P2-P4
G2	90.00°	12-36-60-84	level girdle

CROWN

C1	55.00°	96-24-48-72	set girdle width
C2	55.00°	12-36-60-84	level girdle
C3	42.00°	96-24-48-72	cut as required, size by eye
C4	42.00°	12-36-60-84	meet C1-C2-C3
C5	26.00°	96-24-48-72	cut as required, size by eye
C6	26.00°	12-36-60-84	meet C3-C4-C5
T	0.00°	Table	cut as required, size by eye

Most of the proportions of this stone are achieved by cutting facets 'cut as required, size by eye'
NOT by using a meetpoint sequence.

OPEN SECTION O.10.1

Material:
Facets: 75

Coloured Topaz
Meets: 56 (crown: 27, pavilion: 29)

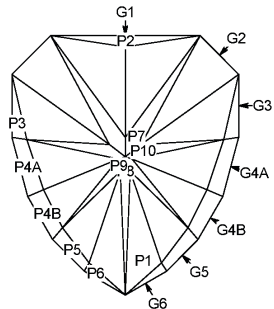
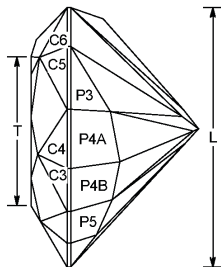
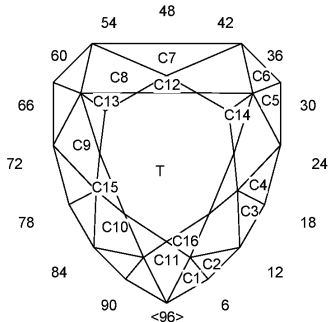

OMNI Shield

by Robert W. Strickland 9/1/97

Computer Work by Rick Parker, for GEMBOREE 2015.
Changed from 'OMNI preform' to 'meet point sequence'.
Angles for R.I. = 1.630

62 + 13 girdles = 75 facets

1-fold, mirror-image symmetry

96 index

L/W = 1.140 T/W = 0.654 U/W = 0.591

P/W = 0.564 C/W = 0.160

Vol./W³ = 0.312

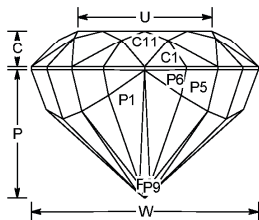

PAVILION

P1	43.20°	02-08-14-22-31-36-43-53-60-65-74-82-88-94	TCP
G1	90.00°	48	sets size
P2	70.80°	48	meet P1-P1-G1 level girdle
G2	90.00°	36-60	meet P1-P1-P2-G1 level girdle
P3	69.30°	24-72	meet P1-P1-G2
G3	90.00°	24-72	meet P1-P1-P3-G2 level girdle
P4A	70.80°	20-76	meet P1-P1-P3
G4A	90.00°	20-76	meet P3-P4A-G3 level girdle
P4B	70.80°	16-80	meet P1-P1-P4A
G4B	90.00°	16-80	meet P4A-P4B-G4A level girdle
P5	69.80°	12-84	meet P1-P1-P4B
G5	90.00°	12-84	meet P4B-P5-G4B level girdle
G6	90.00°	08-88	cut to same depth as G1
P6	69.31°	08.0-88.0	meet P1-P1-P5 level girdle Note 1
P7	42.00°	40-56	meet P1-P1-P2-G1-G2
P8	42.80°	96	meet P1-P1-P6-P6-G6-G6 PCP
P9	42.43°	09.9-86.1	meet P1-P1-P4B-P5 & P1-P1-P8 PCP Note 1
P10	41.68°	28.5-67.5	meet P1-P1-P3-P4A & P1-P1-P7 & P1-P1-P9 PCP Note 1

CROWN

C1	44.20°	08-88	set girdle width
C2	43.90°	12-84	meet C1-G5-G6 level girdle
C3	44.20°	16-80	meet C2-G4B-G5 level girdle
C4	44.90°	20-76	meet C3-G4A-G4B level girdle
C5	45.00°	24-72	meet C4-G3-G4A level girdle
C6	45.60°	36-60	meet C5-G2-G3 level girdle
C7	44.10°	48	meet C6-G1-G2 level girdle
C8	31.60°	44-52	meet C6-C7-G1-G2
C9	38.95°	22-74	meet C4-C5-G3-G4A & C5-C6-C8 Note 1
C10	39.03°	14-82	meet C2-C3-G4B-G5 & C3-C4-C9 Note 1
C11	30.67°	96	meet C1-C1-G6-G6 & C1-C2-C10 Note 1
C12	17.70°	48	meet C7-C8-C8
C13	17.50°	40-56	meet C5-C6-C8-C9
C14	18.20°	26-70	meet C5-C6-C8-C9-C13
C15	21.40°	18-78	meet C3-C4-C9-C10
T	0.00°	96	meet C8-C12-C13 & C9-C14-C15
C16	19.76°	08.9-87.1	meet C1-C2-C10-C11 & C10-C15-T & C11-T Note 1

Note 1: Fine adjustment of angle and/or index may be required to 'meet up' all corners of these facets.

OPEN SECTION O.10.2

Material:

Coloured MM Corundum

Facets: 77

Meets: 57 (crown: 32, pavilion: 25)

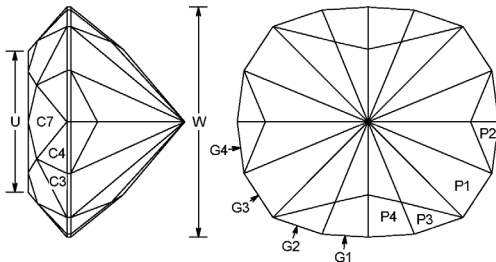
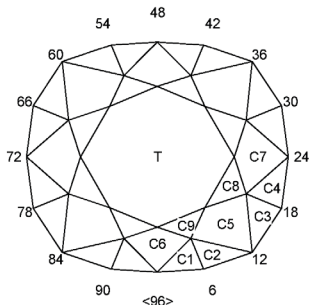

Ultra-brilliant Cushion (Australian Cushion)

Design by John Broadfoot (1998)

Computer Work by Rick Parker, for GEMBOREE 2015.

Angles for R.I. = 1.760

61 + 16 girdles = 77 facets

2-fold, mirror-image symmetry

96 index

L/W = 1.142 T/W = 0.671 U/W = 0.613

P/W = 0.500 C/W = 0.169

Vol./W³ = 0.289

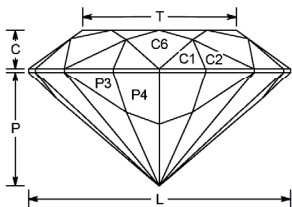

PAVILION

P1	41.00°	03-09-15-21- 27-33-39-45- 51-57-63-69- 75-81-87-93	PCP
G1	90.00°	01-47-49-95	set stone width, girdle not level
G2	90.00°	05-43-53-91	meet P1-P1-G1 girdle not level
G3	90.00°	15-33-63-81	meet P1-P1-G2 level girdle
G4	90.00°	22-26-70-74	meet P1-P1-G3 girdle not level
P2	44.00°	22-26-70-74	meet P1-P1-G3-G4 level girdle
P3	50.00°	05-43-53-91	meet P1-P1-G2-G3 level girdle
P4	51.47°	01-47-49-95	meet P1-P1-P3 & P3-G1-G2 level girdle, Note 1

CROWN

C1	43.20°	01-47-49-95	set girdle width
C2	41.70°	05-43-53-91	meet C1-G1-G2 level girdle
C3	38.90°	15-33-63-81	meet C2-G2-G3 level girdle
C4	39.30°	22-26-70-74	meet C3-G3-G4 level girdle
C5	31.20°	10-38-58-86	meet C2-C3-G2-G3
C6	41.20°	96-48	meet C1-C1-G1-G1 & C1-C2-C5 Note 1
C7	35.67°	24-72	meet C4-C4-G4-G4 & C3-C4-C5 Note 1
C8	16.60°	16-32-64-80	meet C3-C4-C5-C7 Note 2
C9	22.50°	06-42-54-90	meet C1-C2-C5-C6 Note 2
T	0.00°	Table	meet each main facet at associated star facets

Note 1: Fine adjustment of angle and/or index may be required to 'meet up' all corners of these facets.

Note 2: Refer to Note 1, after table has been cut.

INTERMEDIATE SECTION I.10

Material:

Colourless Topaz

Facets: 67

Meets: 50 (crown: 32, pavilion: 18)

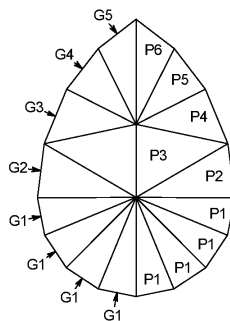
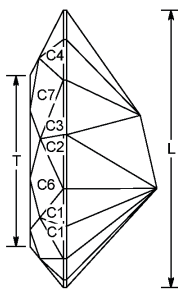
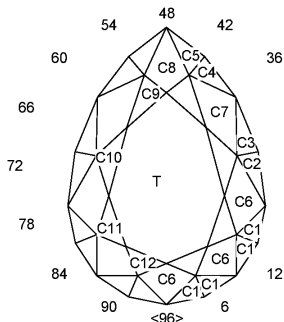

Compear 1:1.40

by Robert W. Strickland 4/9/96

Computer Work by Rick Parker, for GEMBOREE 2015.

Angles for R.I. = 1.630

51 + 16 girdles = 67 facets

1-fold, mirror-image symmetry

96 index

L/W = 1.401 T/W = 0.862 U/W = 0.585

P/W = 0.459 C/W = 0.168

Vol./W³ = 0.300

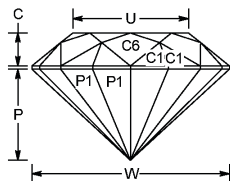

PAVILION

P1	43.10°	03-09-15-21-75-81-87-93	PCP Note 1
P2	42.80°	26-70	meet PCP
P3	41.50°	28-68	meet PCP
G1	90.00°	03-09-15-21-75-81-87-93	set size, level girdle
G2	90.00°	26-70	meet P1-P2-G1 level girdle
G3	90.00°	30-66	meet P2-P3-G2 girdle not level
P4	43.70°	30-66	meet P2-P3-G2-G3 level girdle
P5	44.10°	34-62	meet P3-P3-P4-P4
P6	41.60°	38-58	meet P3-P4-P5
G4	90.00°	34-62	meet P4-P5-G3 level girdle
G5	90.00°	38-58	meet P5-P6-G4 & P6-P6 level girdle

CROWN

C1	45.90°	03-09-15-21-75-81-87-93	set girdle width & level girdle
C2	46.80°	26-70	meet C1-G1-G2 level girdle
C3	47.30°	30-66	meet C2-G2-G3 level girdle
C4	45.40°	34-62	meet C3-G3-G4 level girdle
C5	44.80°	38-58	meet C4-G4-G5 level girdle
C6	39.00°	96-12-24-72-84	meet C1-C1-G1-G1 and last pair at G2
C7	39.20°	32-64	meet C2-C3-C6 & C3-C4-G3-G4 Note 2
C8	26.91°	48	meet C4-C5-C7 & C5-C5-G5-G5 Note 2
C9	17.80°	37-59	meet C4-C5-C7-C8 Note 3
C10	24.50°	28-68	meet C2-C3-C6-C7 Note 3
C11	22.40°	19-77	meet C1-C1-C6-C6 Note 3
C12	23.80°	06-90	meet C1-C1-C6-C6 Note 3
T	0.00°	96	meet each main facet at associated star facets

Note 1: PCP is on the dop stick axis. Diagram has been offset, to allow enlargement, for clarity.

Note 2: Fine adjustment of angle and/or index may be required to 'meet up' all corners of these facets.

Note 3: Refer to Note 2, after table has been cut.

NOVICE SECTION N.10.1

Material:
Facets: 43

Coloured MM Corundum
Meets: 33 (crown: 18, pavilion: 15)

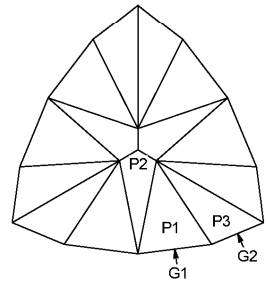
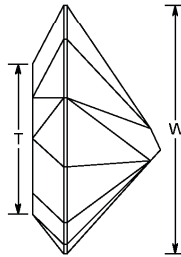
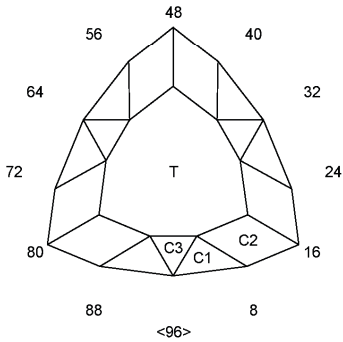

Novice Cushion Triangle

by Robert W. Strickland.

Computer Work by Rick Parker, for GEMBOREE 2015.

Angles for R.I. = 1.760

31 + 12 girdles = 43 facets

3-fold, mirror-image symmetry

96 index

$L/W = 1.010$ $T/W = 0.601$ $U/W = 0.596$

$P/W = 0.376$ $C/W = 0.125$

$Vol./W^3 = 0.153$

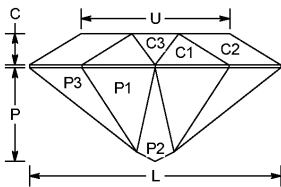

PAVILION

P1	43.00°	02-30-34-62-66-94	TCP
G1	90.00°	02-30-34-62-66-94	set size
P2	42.00°	96-32-64	meet P1-P1-G1-G1 PCP
P3	40.50°	06-26-38-58-70-90	meet P1-P1-P2-P2
G2	90.00°	06-26-38-58-70-90	meet P1-P3-G1 & P3-P3 level girdle

CROWN

C1	40.50°	02-30-34-62-66-94	set girdle width
C2	33.50°	06-26-38-58-70-90	meet C1-G1-G2 level girdle
C3	38.00°	96-32-64	meet C1-C1-G1-G1
T	0.00°	Table	meet C1-C2-C3

OPEN SECTION O.11

Material:

Coloured Natural Quartz

Minimum Size:

8mm (across girdle line)

Facets: 96

Meets: 66 (crown: 25, pavilion: 25, girdle line: 16)

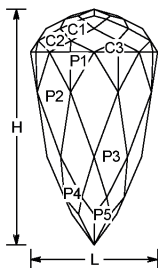
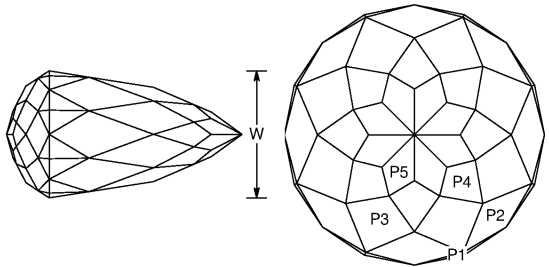
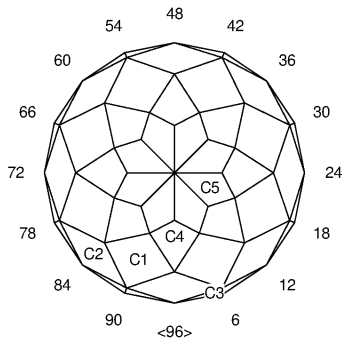

BRIOLETTE

By Paul Sabolta AFG SYDNEY 2007

Computer Work by Rick Parker, for GEMBOREE 2015.

Angles for R.I. = 1.540

96 facets

8-fold, mirror-image symmetry

96 index

L/W = 1.000

H/W = 1.856

Vol./W³ = 0.765

CROWN

C1	37.00°	06-18-30-42-54-66-78-90	TCP
C2	57.00°	96-12-24-36-48-60-72-84	size stone Note 2
C3	77.00°	03-09-15-21-27-33-39-45-51-57-63-69-75-81-87-93	meet C1-C2-C2
C4	27.00°	96-12-24-36-48-60-72-84	meet C1-C1-C2 TCP
C5	17.00°	06-18-30-42-54-66-78-90	meet C1-C4-C4 PCP

PAVILION

P1	88.00°	03-09-15-21-27-33-39-45-51-57-63-69-75-81-87-93	meet C2-C3-C3 makes girdle line
P2	81.20°	96-12-24-36-48-60-72-84	meet C2-C3-C3-P1-P1
P3	74.20°	06-18-30-42-54-66-78-90	meet P1-P1-P2-P2
P4	66.60°	96-12-24-36-48-60-72-84	meet P2-P3-P3
P5	56.00°	06-18-30-42-54-66-78-90	meet P3-P4-P4 PCP

Note 1: Top & Bottom view of the Diagram have been enlarged for clarity.

Note 2: Diameter of finished stone is only slightly larger than diameter made by the tips of tier C1.

INTERMEDIATE SECTION I.11

Material: Coloured MM Spinel
 Minimum Size: 10mm ('W' on the diagram)
 Facets: 60
 Meets: 34 (crown: 17, pavilion: 17)

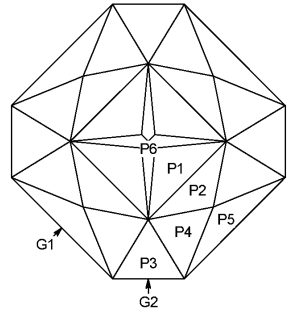
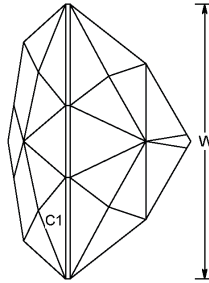
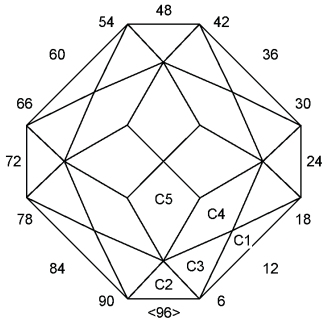

Joker

by Greg Glenn
 Computer Work by Rick Parker, for GEMBOREE 2015.
 Angles for R.I. = 1.718
 52 + 8 girdles = 60 facets
 4-fold, mirror-image symmetry
 96 index
 L/W = 1.000
 P/W = 0.440 C/W = 0.211
 Vol./W³ = 0.223

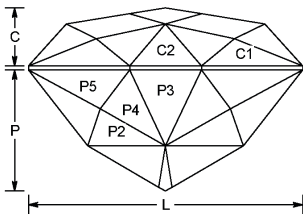

PAVILION

P1	42.00°	12-36-60-84	TCP
P2	45.00°	12-36-60-84	cut by eye Note 1
P3	52.00°	96-24-48-72	meet P1-P1-P2-P2
P4	48.00°	11-13-35-37-59-61-83-85	meet P1-P1-P2-P2-P3
P5	52.00°	12-36-60-84	meet P2-P4-P4
G1	90.00°	12-36-60-84	meet P3-P4-P5 position girdle, this will be stone size
G2	90.00°	96-24-48-72	meet P3-P4-P5-G1 level girdle
P6	30.00°	96-24-48-72	meet P1-P1-P2-P2-P3-P4-PCP

CROWN

C1	48.00°	12-36-60-84	set girdle width
C2	48.00°	96-24-48-72	level girdle
C3	39.00°	10-14-34-38-58-62-82-86	meet C1-C2-G1-G2
C4	28.11°	12-36-60-84	meet C1-C3-C3 & C2-C3-C3 Note 2
C5	9.00°	96-24-48-72	meet C2-C3-C3-C4-C4 PCP

Note 1: The length of the edge between facets P1 and P2 will be approx 40% of the finished stone width 'W'.
 Note 2: Fine adjustment of angle and/or index may be required to 'meet up' all corners of these facets.



GEMBOREE 2015

Proudly Hosted by
Victorian Gem Clubs Association Inc.

PO Box 642
RINGWOOD VIC 3134
www.victoriangemclubs.asn.au

Member Clubs

AUSTRALIAN FACETORS' GUILD LTD. (VIC BRANCH)

C/- 49 Salmond St DEER PARK VIC 3023

ALBURY LAPIDARY & ALLIED CRAFTS INC.

P O Box 677 ALBURY NSW 2640

ALEXANDRA EILDON LAPIDARY CLUB INC.

P O Box 261 ALEXANDRA VIC 3714

BAIRNSDALE LAPIDARY CLUB INC.

P O Box 431 BAIRNSDALE VIC 3875

BALLARAT & DISTRICT GEM CLUB INC.

P O Box 736 BALLARAT VIC 3350

BENDIGO GEM CLUB INC.

P O Box 1059 BENDIGO VIC 3552

BENDIGO PROSPECTORS CLUB INC.

P O Box 2497 BENDIGO MC VIC 3554

BLUE HILLS LAPIDARY CLUB INC.

C/- 6 Kitchener Pde COCKATOO VIC 3781

CHEONG PARK GEM & MINERAL CLUB INC.

P O Box 219 CROYDON VIC 3136

COLAC & DISTRICT GEM CLUB INC.

C/- 70 Polwarth St COLAC VIC 3250

DANDENONG LAPIDARY CLUB INC.

P O Box 59 DOVETON VIC 3177

DIAMOND VALLEY GEM CLUB INC.

P O Box 335 GREENSBOROUGH VIC 3088

ESSENDON GEM & LAPIDARY CLUB INC.

P O Box 97 ESSENDON VIC 3040

FRANKSTON & PENINSULA LAPIDARY CLUB INC.

P O Box 7230 Karingal Centre LPO FRANKSTON VIC 3199

G.A.A. (VICTORIAN DIVISION INC.)

Gemmology House 380-382 Spencer Street
WEST MELBOURNE VIC 3003

GEELONG GEM & MINERAL CLUB INC.

P O Box 662 GEELONG VIC 3220

GV GEM MINERAL & CRAFT GROUP

C/- 12 Gilchrist Street SHEPPARTON VIC 3630

HORSHAM & DISTRICT LAPIDARY CLUB INC.

P O Box 828 HORSHAM VIC 3402

MAROONDAH GEM CLUB INC.

C/- 1885 Healesville-Kooweerup Rd
YELLINGBO VIC 3139

McMILLAN ROCKHOUNDS INC.

P O Box 202 MAFFRA VIC 3860

MILDURA & DISTRICT GEM & MINERAL CLUB INC.

P O Box 736 MILDURA VIC 3502

MORDIALLOC LAPIDARY CLUB INC.

49-51 Albert Street MORDIALLOC VIC 3195

MORWELL LAPIDARY CLUB INC.

P O Box 3501 MORWELL MC VIC 3841

MOUNT GAMBIER GEM CLUB INC.

P O Box 1478 MOUNT GAMBIER SA 5290

NUNAWADING & DISTRICT LAPIDARY CLUB INC.

P O Box 69 NUNAWADING VIC 3131

RUSHWORTH PROSPECTING CLUB INC.

C/- 15 Heily St RUSHWORTH VIC 3612

SHEPPARTON GEM CLUB INC.

P O Box 1510 SHEPPARTON VIC 3631

STH GIPPSLAND GEM & LAPIDARY CLUB INC.

C/- 10 Princes Street KORUMBURRA VIC 3950

SUNBURY METAL DETECTING CLUB INC.

P O Box 496 CRAIGIEBURN VIC 3064

WAGGA WAGGA RIVERINA LAPIDARY CLUB INC.

PO Box 276 WAGGA WAGGA NSW 2650

WARRAGUL & DISTRICT LAPIDARY CLUB INC.

P O Box 96 DARNUM VIC 3822

WARRNAMBOOL GEM CLUB INC.

P O Box 18 WARRNAMBOOL VIC 3280

WAVERLEY GEM CLUB INC.

P O Box 255 GLEN WAVERLEY VIC 3150

WESTERN SUBURBS LAPIDARY CLUB OF VIC INC.

C/- 72 Vernon St SPOTSWOOD VIC 3015



GEMBOREE 2015 REGISTRATION FORM

MAIL TO: GEMBOREE 2015, C/- J Medew 4 Kelleher St CHURCHILL VIC 3842

(Please enclose stamped, self addressed envelope for return of receipt.)

NOTE: *Registration covers from noon Wednesday 1st April to noon Tuesday 7th April 2015. No refunds for cancellations after 1st February 2015, except in unusual circumstances. Earliest entry to Campsite is 12 noon Wednesday 1st April, Sites MUST be vacated by 12 noon Tuesday 7th April 2015. Pets are permitted, owners shall be responsible for their conduct.*

GENERATORS ARE NOT PERMITTED

**VENUE ADDRESS: Wimmera Events Centre,
Longerenong Rd; via Horsham,
DOOEN; via Henty Hwy.**

(Please Print Clearly)

Surname: **Given Names:**

Address:

Postcode: **Phone:** **Club:**

CAMPSITE ACCOMMODATION: *Be sure to indicate whether you have an annexe.*

CARAVANm X m	ANNEXEm X m	(YES/NO)
CAMPERm X m	ANNEXEm X m	(YES/NO)
TENTm X m				
CLOSE TO TOILETS	(YES/NO)	DISABILITY	(YES/NO)	

ON-SITE FEES: *For 2 Adults & up to 4 Children (school age). Sites approx. 6m x 9m*

POWERED SITE		\$120.00	\$
UNPOWERED SITE		\$100.00	\$
EXTRA VEHICLE		\$5.00	\$
EXTRA ADULTS	No.	@ \$25.00	\$
EXTRA CHILD (10-16yr)	No.	@ \$5.00	\$

Bus Sites are available by request.

Air Conditioners, Radiators, Electric Jugs, Frypans & Microwaves

ARE PERMITTED, BUT as with any caravan park, DON'T HAVE TOO MANY ON AT ONCE.

Caravanners, please fill your water tanks prior to arrival on site.

OFF-SITE FEES: *Per person for duration of GEMBOREE.*

ADULTS	No.	@ \$24.00	\$
CHILDREN (10-16yr)	No.	@ \$5.00	\$

SOUVENIRS:

GEMBOREE BADGES	No.	@ \$6.00	\$
-----------------	----------	----------	----	-------

TOTAL Enclosed *(Cheque/Money Order)* \$

Please make all cheques payable to: "Victorian Gem Clubs Association Inc. GEMBOREE Account"

VOLUNTARY ASSISTANCE AT GEMBOREE 2015



MAIL TO: GEMBOREE 2015, C/- J Medew 4 Kelleher St CHURCHILL VIC 3842
Or contact GEMBOREE Secretary, Des McKiernan on 0428 303 160.

To arrive no later than January 31st 2015.

Please offer some of your time to help make the GEMBOREE more enjoyable for everyone. Your help will be greatly appreciated. Please indicate below which areas, days and times you are willing to assist. The major areas in which we need help are:

- **CAMPSITE MARKING etc** - From Tuesday March 31st.
- **CAMPSITE GATES** - From noon Wednesday, including overnight Wednesday & Thursday.
- **EXHIBITION SETTING UP** - From Wednesday am.
- **EXHIBITION DOORS** - From noon Friday to Monday closing.
- **EXHIBITION HALL STEWARD** - During opening hours of the Show.
- **EXHIBITION DISMANTLING.**
- **CAMPSITE CLEAN-UP, TRESTLE LOADING etc.**
- **OTHER ASSISTANCE** - Please specify.

(Please Print Clearly)

NAME:

ADDRESS:

STATE: POSTCODE: PHONE:

Area(s) where you are offering to help:

.....
.....
.....

Times you are available, between Tuesday 31st March to Tuesday 7th April 2015:

.....
.....
.....



TAILGATING APPLICATION FORM (PRIVATE / NON-COMMERCIAL) GEMBOREE 2015

I wish to apply for **Private/Non-commercial** Tailgating at the 2015 GEMBOREE in Horsham.
I have read the **'Terms and Conditions'** and by signing this form, both my assistants and I agree to abide by them.
(Please Print Clearly)

Surname: **First Name:**

Address: **Post Code:**

Phone: **Mobile:** **Email:**

DATES: Friday 3rd April / Saturday 4th April / Sunday 5th April / Monday 6th April

PLEASE CIRCLE THE DAYS ABOVE ON WHICH YOU WISH TO TAILGATE

FEES: **\$45.00 PER DAY** or part thereof for up to 4 Metres or 12' Site.
Note: (Price includes Compulsory Public Liability Insurance at \$15/day.⁹)

PAYMENT: Tailgating Fee Day/s @ \$45.00 per day \$

Extra Site/s X Day/s @ \$30.00 per day \$

Registration Fee X Day/s @ \$8.00 per day \$

(Per Adult if you have not registered a Campsite or as staying Off Site.)

TOTAL Enclosed (Cheque/Money Order) \$

DECLARATION: I am a casual amateur tailgater who **does not have a business name** and/or **does not buy stock for the purpose of re-selling**. I have also read, and will abide by the **Terms and Conditions** below.

Signed: **Date:**

Please Note: *If you do have a business name and/or buy stock for the purpose of re-selling, or have your own insurance; you **MUST** use the "Commercial" Tailgating Application Form!*

Terms and Conditions:

1. I will abide by the following terms and conditions to Tailgating at the GEMBOREE 2015.
2. I am a Hobbyist and do not earn monies from any Commercial/Semi-commercial phase of the Hobby, eg. Mining, Dealing, Full-time cutting or Manufacture. I will not make credit card facilities available.
3. I will sell only material which is surplus from my Hobby activities, eg. Field collecting, up-grading my collections and/or items made by me and which will be of a lapidary nature or lapidary related.
4. The material for sale has not been purchased specially for resale, except for commercially made findings used in jewellery making.
5. I will trade only within the times and areas allotted to me by the Organisers. Tailgating sites to be cleared at end of trading times each day. Camping prohibited in tailgating area.
6. I will trade in a respectful manner at all times and follow instructions from the organising committee.
7. Application to Tailgating does not entitle me to trade, except upon acceptance by the Organisers and receipt of the Permit to Trade.
8. I agree to pay the appropriate registration fee as a participant of GEMBOREE 2015 and also to pay the required fees for Tailgating.
9. Public Liability Insurance at \$15/day is current at the time of printing and is subject to change without notice.
10. Should I contravene any part of these terms, I agree to vacate the GEMBOREE 2015 site and forfeit all monies paid.

PLEASE MAKE ALL CHEQUES PAYABLE TO: "Victorian Gem Clubs Association Inc. GEMBOREE Account"

MAIL TO: GEMBOREE 2015 Bookings, 351 Lockharts Gap Road, SANDY CREEK VIC 3695
(Please Note: A stamped self addressed envelope 110x220 must be included.)

ENQUIRIES: Mrs Joan Barrows (Tailgating Co-ordinator.)
EMAIL: joaba99@optusnet.com

Ph: (02) 6021 5043 **Mobile:** 0427 535 470
WEBSITE: www.victoriangemclubs.asn.au



TAILGATING APPLICATION FORM (COMMERCIAL) GEMBOREE 2015

I wish to apply for **Commercial** Tailgating at the 2015 GEMBOREE in Horsham.
I have read the **'Terms and Conditions'** and by signing this form, both my assistants and I agree to abide by them.
(Please Print Clearly)

Surname: **First Name:**

Address: **Post Code:**

Phone: **Mobile:** **Email:**

DATES: Friday 3rd April / Saturday 4th April / Sunday 5th April / Monday 6th April

PLEASE CIRCLE THE DAYS ABOVE ON WHICH YOU WISH TO TAILGATE

FEES: **\$50.00 PER DAY** or part thereof for up to 4 Metres or 12' Site.
Note: (A copy of your Public Liability Insurance cover **MUST** be attached to this Application Form.)

PAYMENT: Tailgating Fee Day/s @ \$50.00 per day \$

Extra Site/s X Day/s @ \$50.00 per day \$

Registration Fee X Day/s @ \$8.00 per day \$

(Per Adult if you have not registered a Campsite or as staying Off Site.)

TOTAL Enclosed (Cheque/Money Order) \$

DECLARATION: I have attached a copy of my Public Liability Insurance policy with a minimum cover of \$10M that will be valid at the time of this event. I have also read, and will abide by the **Terms and Conditions** below.

Signed: **Date:**

Please Note: If you do not have a business name and/or do not buy stock for the purpose of re-selling, you **may** be eligible to use the "Private/Non-Commercial" Tailgating Application Form!
(Please check all 'Terms and Conditions' first to ensure if you are eligible.)

Terms and Conditions:

1. I will abide by the following terms and conditions to Tailgating at the GEMBOREE 2015.
2. I will sell only items or material, which will be of a lapidary nature or lapidary related.
3. I will trade only within the times and areas allotted to me by the Organisers. Tailgating sites to be cleared at end of trading times each day. Camping prohibited in tailgating area.
4. I will trade in a respectful manner at all times and follow instructions from the organising committee.
5. Application to Tailgating does not entitle me to trade, except upon acceptance by the Organisers and receipt of the Permit to Trade.
6. I agree to pay the appropriate registration fee as a participant of GEMBOREE 2015 and also to pay the required fees for Tailgating.
7. A copy of your Public Liability Insurance cover with a minimum cover of \$10M that will be valid at the time of this event **MUST** be attached to this Application Form. Insurance is available from Webster Hyde Heath Insurance Brokers Pty Ltd. Ph. (08) 8362 5553
8. Application forms lodged without a copy of the insurance policy **will not be accepted**, and will be returned.
9. VGCA is not able to provide Public Liability Insurance for Commercial Tailgaters.
10. Should I contravene any part of these terms, I agree to vacate the GEMBOREE 2015 site and forfeit all monies paid.

PLEASE MAKE ALL CHEQUES PAYABLE TO: "Victorian Gem Clubs Association Inc. GEMBOREE Account"

MAIL TO: GEMBOREE 2015 Bookings, 351 Lockharts Gap Road, SANDY CREEK VIC 3695

(Please Note: A stamped self addressed envelope 110x220 must be included.)

ENQUIRIES: Mrs Joan Barrows (Tailgating Co-ordinator.)

Ph: (02) 6021 5043 **Mobile:** 0427 535 470

EMAIL: joaba99@optusnet.com

WEBSITE: www.victoriangemclubs.asn.au